

Straight Talk About Directivity

Bird Technologies Group Applications Engineer

Application Note: Effects of Directivity on Power, VSWR and Return Loss Measurement Accuracy

Introduction

Directivity plays a critical role in determining the accuracy of your RF power, VSWR and return loss measurements. Errors due to directivity can be significant and may influence the decisions you make based upon your test results. The purpose of this article is to explore the subject of directivity and to set appropriate expectations.

Figure 1 and Examples 1 & 2 illustrate the effects of directivity. As you can see, an in-line power meter or antenna monitor with 25 dB of directivity will produce measurements with a wide margin of error when compared with those of a 40 dB device. This could make the difference between judging your antenna as in or out of specification. This may also cause false alarm conditions when monitoring your antenna (i.e. alarm when all is well or, worse yet, no alarm when there actually is a problem!)

A step-by-step procedure to arrive at these figures in a straightforward manner is discussed later in this paper. For your convenience, the "Directivity Chart" which lists error ranges for given VSWR and return loss levels may be found in the appendix of this application note. You can also readily perform this analysis and several others for your specific application by downloading a complimentary copy of the "RF Calculator" at www.bird-electronic.com.

Example 1: Directivity of 25 dB

Power meter or antenna monitor specification:
25 dB directivity

Antenna VSWR (actual):
1.50 VSWR (-14.0 dB return loss)
VSWR measurement range:
1.33 to 1.70 VSWR (-16.9 to -11.7 dB return loss)
VSWR measurement errors:
-0.17 to +0.20 VSWR (-2.9 to +2.3 dB return loss)

Forward power from transmitter (actual): 100.0 W
Forward power measured range: 97.8 to 102.3 W
Forward power measured errors: **-2.2% to +2.3% W**

Reflected power from antenna (actual): 4.0 W
Reflected power measured range: 2.1 to 6.6 W
Reflected power measured errors: **-48% to +64% W**

Figure 1: Directivity

The accuracy of your measurements depends upon the directivity of your power meter or antenna monitor

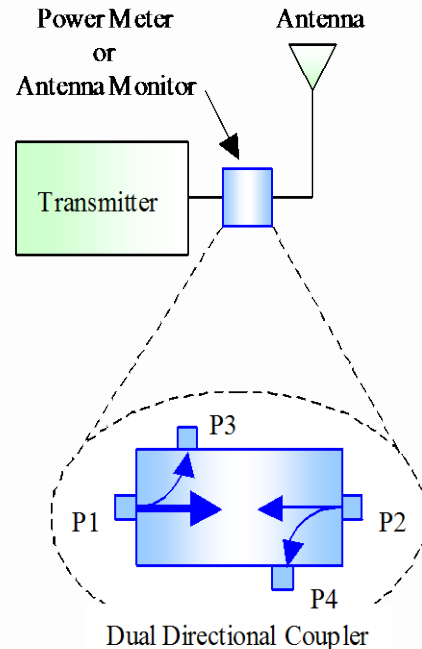

Example 2: Directivity of 40 dB

Power meter or antenna monitor specification:
40 dB directivity

Antenna VSWR (actual):
1.50 VSWR (-14.0 dB return loss)
VSWR measurement range:
1.47 to 1.53 VSWR (-14.4 to -13.5 dB return loss)
VSWR measurement errors:
-0.03 to +0.03 VSWR (-0.4 to +0.5 dB return loss)

Forward power from transmitter (actual): 100.0 W
Forward power measured range: 99.6 to 100.4 W
Forward power measured errors: **-0.4% to +0.4% W**

Reflected power from antenna (actual): 4.0 W
Reflected power measured range: 3.6 to 4.4 W
Reflected power measured errors: **-10% to +10% W**

Straight Talk About Directivity

Bird Technologies Group Applications Engineer

Directivity

Directivity is a measure, or figure of merit, as to the ability of a directional coupler to discern between the forward and reflected traveling wave in the transmission system. Directivity in the directional coupler is established by balancing the contribution in the coupler circuit from the electric field component and the magnetic field component. When the contribution from these two sources are balanced the coupler directivity is optimized. The electric and magnetic field contributions are determined by the coupling capacitor and inductor on the coupling plate.

Directional Coupler

A directional coupler is a passive device that is used to provide a sample of the power in a transmission line, and is capable of discerning between the forward and reflected traveling wave. Specifically, a directional coupler measures forward and reflected power as well as VSWR and return loss. It is also a key component in power meters, antenna monitors and analyzers.

The directional coupler works by providing two samples of the quantities in the transmission line. One sample is derived from coupling to the electric field in the line, where the other sample is derived from coupling to the magnetic field in the line. The two samples are summed, resulting in an additive condition in the forward orientation, and a subtractive condition in the reflected orientation.

Per Figures 1 & 2, dual directional couplers have of a pair of main ports (i.e. forward and reflected) and a pair of coupled output ports (also forward and reflected). Power input to the main forward port (P1) will produce a power sample at the coupled forward port (P3). This forward power sample will be equivalent to the main input power reduced by a coupling factor. A reflected power sample will also be produced at the coupled reflected port (P4) when power is presented at the main reflected port (P2).

Basic formulas required to calculate coupled power include:

Coupled Power
= Main Power / Coupling Power Ratio

Power Ratio = $10^{(dB / 10)}$

As an example, a 100 W main power input to a directional coupler with a coupling factor of 30 dB will produce:

Coupled Power = $100 \text{ W} / 10^{(30 \text{ dB} / 10)} = 100 \text{ mW}$.

Thus, 100 W input to the main forward port (P1) will produce a 100 mW output at the coupled forward port (P3). At the same time, 4 W reflected into the main reflected port (P2) will generate a 4 mW sample at the coupled reflected port (P4). Note, these figures assume that the coupled reflected port (P4) is perfectly isolated from the main forward port (P1). Also, the coupled forward port (P3) is ideally isolated from the main reflected port (P2).

Measuring Directivity

In practice, there is finite isolation between these ports. The difference between this isolation value and the coupling factor defines the coupler's directivity. A vector network analyzer may be used to determine directivity by measuring the isolation and coupling factor.

Figure 2: Isolation Measurement

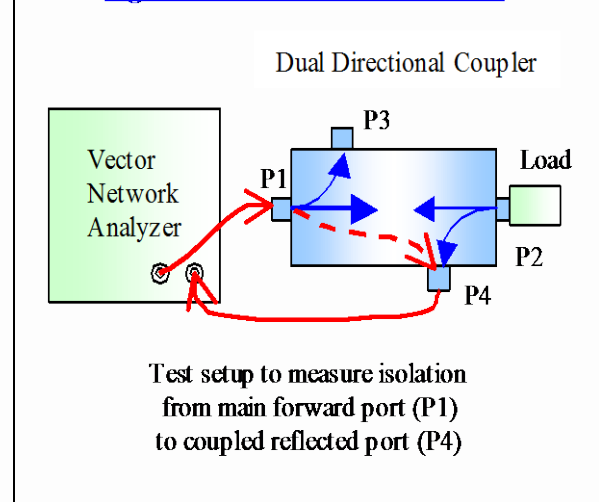

Test setup to measure isolation from main forward port (P1) to coupled reflected port (P4)

Per Figure 2, isolation is derived by stimulating the main forward port (P1) and measuring the output at the coupled reflected port (P4) with a good load on the main reflected port (P2). The coupler is then reversed to test the coupling factor. The main reflected port (P2) is stimulated while the output of the coupled reflected port (P4) is measured with the load connected to the main forward port (P1).

In a dual directional coupler the coupling factor from the main reflected (P2) to the coupled reflected (P4) port is the same as the coupling factor from the main

Straight Talk About Directivity

Bird Technologies Group Applications Engineer

forward (P1) to the coupled forward (P3) port. Also, isolation from the main forward (P1) to the coupled reflected (P4) port is equal to the isolation from the main reflected (P2) to the coupled forward (P3) port. With isolation and coupling values in hand directivity is:

$$\text{Directivity (dB)} = \text{Isolation (dB)} - \text{Coupling (dB)}$$

For example, if the isolation measured is 55 dB and the coupling factor is 30 dB then the directional coupler's directivity is 25 dB = 55 dB - 30 dB.

Directivity Errors

Due to the coupler's limited isolation, power input to the main forward port (P1) will produce power at the coupled reflected port (P4). You may think of this as a portion of forward power (P1) unintentionally "leaking" into the coupled reflected port (P4). This leakage power will be equivalent to the main input power reduced by the isolation value. Similarly, power will be produced at the coupled forward port (P3) when power is presented at the main reflected port (P2). As you will see, this finite isolation is the root cause for directivity errors.

An interesting situation now exists, each of the coupled ports produces two outputs, one from each of the two main ports. The coupled reflected port (P4) produces outputs from the main reflected (P2, less coupling) and forward (P1, less isolation) ports. Likewise, the coupled forward port (P3) outputs power from the main forward (P1, less coupling) and reflected (P2, less isolation) ports.

Power meters measure the main line power by taking the directional coupler outputs at the coupled ports and effectively increasing by the coupling factor. The main reflected power (P2) measured by the power meter is equal to the combination of two power levels. These two powers are the coupled reflected power (P4) increased by the coupling factor and main forward power (P1) reduced by isolation and increased by the coupling factor.

This is equivalent to combining the main reflected power (P2) with main forward power (P1) reduced by directivity = isolation - coupling. Since these combined powers are measured by the power meter as reflected power, this is essentially combining the main reflected power with an error component (i.e. the reflected power due to directivity).

This process may be logically mapped in the following way:

Main Reflected Power

$$= (\text{Coupled Reflected Power} + \text{Coupling Factor}) + (\text{Main Forward Power} - \text{Isolation} + \text{Coupling Factor})$$

$$= \text{Main Reflected Power} + (\text{Main Forward Power} - \text{Directivity})$$

$$= \text{Main Reflected Power} + \text{Directivity Reflected Power}$$

Likewise, power meters derive main forward power from a combination of the main forward power and an error component, directivity forward power.

Main Forward Power

$$= (\text{Coupled Forward Power} + \text{Coupling Factor}) + (\text{Main Reflected Power} - \text{Isolation} + \text{Coupling Factor})$$

$$= \text{Main Forward Power} + (\text{Main Reflected Power} - \text{Directivity})$$

$$= \text{Main Forward Power} + \text{Directivity Forward Power}$$

Power and Voltage

When the main reflected power is combined with the directivity reflected power it is not a case of simple addition. To begin, powers must be converted to voltages. The two voltages are then combined using vector math, resulting in minimum and maximum voltage levels. The resultant voltages are then converted back to minimum and maximum powers. These minimum and maximum levels constitute directivity error ranges. The same process holds true when combining the main forward power with the directivity forward power.

Power and voltage formulas are:

$$\text{Power} = \text{Voltage}^2 / \text{Impedance}$$

$$\text{Voltage} = \text{Square Root} (\text{Power} \times \text{Impedance})$$

Example, 4 W in a 50 Ohm system yields
 $14 \text{ V} = \text{Sqrt} (4 \text{ W} \times 50 \text{ Ohms})$.

Straight Talk About Directivity

Bird Technologies Group Applications Engineer

When voltages are combined vector math is required. Voltages may be viewed as vectors with a magnitude and phase. Since the phase of the voltage vectors are unknown the extreme cases (i.e. voltages combine in or out-of-phase) need to be taken into account. A voltage minimum results when two voltages combine 180 degrees out-of-phase with each other. When they combine in-phase the result is a voltage maximum.

Voltage Minimum = Voltage A – Voltage B

Voltage Maximum = Voltage A + Voltage B

Per figure 3, combining 14 V and 4 V produces:

Voltage Minimum = 14 V – 4 V = 10 V

Voltage Maximum = 14 V + 4 V = 18 V

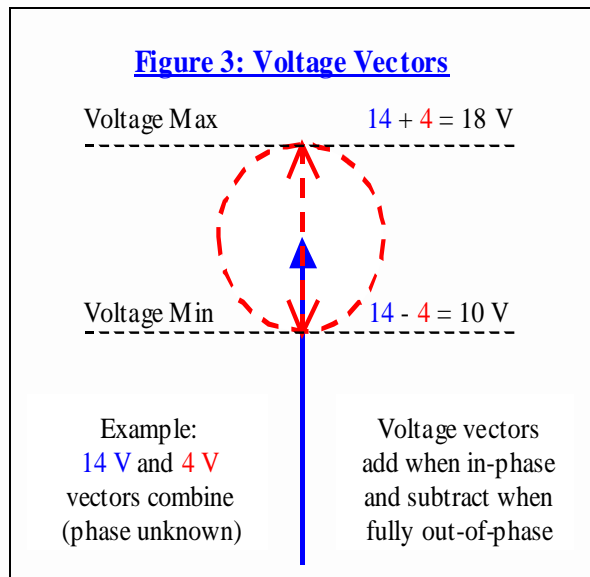

Once the minimum and maximum voltages are determined they can be converted back to power values. These forward and reflected power levels may then be used to calculate VSWR and Return Loss, including minimum and maximum values as well.

VSWR and Return Loss

Voltage Standing Wave Ratio (VSWR) and Return Loss are both complex ratios of forward and reflected power. Rho is also a ratio of these powers and is often used as an interim step in computing VSWR.

$\text{Rho} = \text{Sqrt} (\text{Reflected Power} / \text{Forward Power})$

$\text{VSWR} = (1 + \text{Rho}) / (1 - \text{Rho})$

Return Loss
 $= 10 \text{ Log} (\text{Reflected Power} / \text{Forward Power})$

Example, with a forward power of 100 W and reflected power of 4 W:

$\text{Rho} = \text{Sqrt} (4 \text{ W} / 100 \text{ W}) = 0.2$

$\text{VSWR} = (1 + 0.2) / (1 - 0.2) = 1.5$

Return Loss = 10 Log (4W / 100 W) = -14 dB

Reflected power may also be calculated if VSWR (or return loss) and forward power are known:

Reflected Power
 $= \text{Forward Power} [(\text{VSWR} - 1) / (\text{VSWR} + 1)]^2$

Reflected Power
 $= \text{Forward Power} \times 10^{(\text{Return Loss dB} / 10)}$

For example, with a 1.5 VSWR (-14 dB return loss) and 100 W forward power:

Reflected Power =
 $100 \text{ W} [(1.5 - 1) / (1.5 + 1)]^2 = 4 \text{ W}$

Reflected Power = $100 \text{ W} \times 10^{(-14 \text{ dB} / 10)} = 4 \text{ W}$

For your reference, a VSWR and Return Loss chart is located in the appendix of this document.

Step-by-Step Procedure

To review, directional couplers have finite directivity which causes measurement errors. In turn, coupler based devices such as power meters and antenna monitors produce power, VSWR and return loss measurements within a range of uncertainty. The following exercise quantifies these directivity errors with a step-by-step procedure.

Straight Talk About Directivity

Bird Technologies Group Applications Engineer

Referring to Figure 1 and Example 1 at the introduction of this paper, a 100 W transmitter is connected to an antenna specified with a 1.5 VSWR (-14 dB return loss). A power meter or antenna monitor with a 25 dB directivity specification is used to make power, VSWR and return loss measurements. Assuming all of this 50 ohm equipment is performing to specification, what are the measurement errors due to directivity?

Step 1) Reflected Power

We will begin by calculating the directivity errors associated with reflected power measurements. Directivity has a great impact on reflected power measurements because reflected power levels are relatively low when compared with forward power. Even a small amount of forward power "leakage" (i.e. directivity reflected power) can cause large percentage errors in reflected power measurements.

1a) List Known Values

Power meter or antenna monitor specification
= 25 dB directivity

Antenna specification
= 1.50 VSWR (-14.0 return loss)

Forward power from transmitter = 100 W

System impedance = 50 Ohms

1b) Directivity Reflected Power

Directivity Power Ratio
 $= 10^{(Directivity / 10)} = 10^{(25 \text{ dB} / 10)} = 316$

Directivity Reflected Power
= Forward Power / Directivity Power Ratio
= 100 W / 316 = 316 mW

1c) Directivity Reflected Voltage

Directivity Reflected Voltage
= Square Root (Directivity Reflected Power x Impedance)
= Sqrt (316 mW x 50 Ohms) = 3.976 V

1d) Reflected Power

Reflected Power
= Forward Power [(VSWR - 1) / (VSWR + 1)]²
= 100 W [(1.5 - 1) / (1.5 + 1)]² = 4 W

1e) Reflected Voltage

Reflected Voltage
= Square Root (Reflected Power x Impedance)
= Sqrt (4 W x 50 Ohms) = 14.142 V

1f) Reflected Voltage Min and Max

Reflected Voltage Minimum
= Reflected Voltage - Directivity Reflected Voltage
= 14.142 V - 3.976 V = 10.166 V

(Note, in cases where the Directivity Reflected Voltage is greater than or equal to the Reflected Voltage, the Reflected Voltage Minimum is 0 V)

Reflected Voltage Maximum
= Reflected Voltage + Directivity Reflected Voltage
= 14.142 V + 3.976 V = 18.118 V

1g) Reflected Power Min and Max

Reflected Power Minimum
= Reflected Voltage Minimum² / Impedance
= 10.166 V² / 50 Ohms = 2.067 W

Reflected Power Maximum
= Reflected Voltage Maximum² / Impedance
= 18.118 V² / 50 Ohms = 6.566 W

1h) Reflected Power Min and Max Error

Reflected Power Min Error
= 100% [(Reflect Power Min / Reflect Power) - 1]
= 100% [(2.067 W / 4 W) - 1] = -48%

Reflected Power Max Error
= 100% [(Reflect Power Max / Reflect Power) - 1]
= 100% [(6.566 W / 4 W) - 1] = 64%

Step 2) Forward Power

The next step is to calculate directivity errors associated with forward power measurements. Directivity has less of an effect on forward power measurements because forward power is relatively large when compared with reflected power. However, reflected power "leakage" (i.e. directivity forward power) does cause small percentage errors in forward power measurements. This may or may not be significant depending upon your application.

Straight Talk About Directivity

Bird Technologies Group Applications Engineer

2a) List Known Values

Power meter or antenna monitor specification
= 25 dB directivity

Antenna specification
= 1.50 VSWR (-14.0 return loss)

Forward power from transmitter = 100 W

Reflected power from antenna = 4 W

System impedance = 50 Ohms

2b) Directivity Forward Power

Directivity Power Ratio
 $= 10^{(Directivity / 10)} = 10^{(25 \text{ dB} / 10)} = 316$

Directivity Forward Power
= Reflected Power / Directivity Power Ratio
= 4 W / 316 = 0.013 W = 12.7 mW

2c) Directivity Forward Voltage

Directivity Forward Voltage
= Square Root (Directivity Forward Power x Impedance)
= Sqrt (12.7 mW x 50 Ohms) = 0.795 V

2d) Forward Voltage

Forward Voltage
= Square Root (Forward Power x Impedance)
= Sqrt (100 W x 50 Ohms) = 70.711 V

2e) Forward Voltage Min and Max

Forward Voltage Minimum
= Forward Voltage - Directivity Forward Voltage
= 70.711 V - 0.795 V = 69.915 V

Forward Voltage Maximum
= Forward Voltage + Directivity Forward Voltage
= 70.711 + 0.795 V = 71.506 V

2f) Forward Power Min and Max

Forward Power Minimum
= Forward Voltage Minimum² / Impedance
= 69.915 V² / 50 Ohms = 97.763 W

Forward Power Maximum
= Forward Voltage Maximum² / Impedance
= 71.506 V² / 50 Ohms = 102.262 W

2g) Forward Power Min and Max Error

Forward Power Min Error
= 100% [(Forward Power Min / Forward Power) - 1]
= 100% [(97.763 W / 100 W) - 1] = -2.2%

Forward Power Max Error
= 100% [(Forward Power Max / Forward Power) - 1]
= 100% [(102.262 W / 100 W) - 1] = 2.3%

Step 3) VSWR and Return Loss

Finally, directivity errors associated with VSWR and Return Loss measurements are also calculated. Directivity impacts both forward and reflected power and in turn influences VSWR and Return Loss as well.

3a) List Known Values

Power meter or antenna monitor specification
= 25 dB directivity

Antenna specification
= 1.50 VSWR (-14.0 return loss)

Forward power min from transmitter = 97.763 W

Forward power (actual) from transmit = 100.000 W

Forward power max from transmitter = 102.262 W

Reflected power minimum from antenna = 2.067 W

Reflected power (actual) from antenna = 4.000 W

Reflected power maximum from antenna = 6.566 W

System impedance = 50 Ohms

3b) VSWR Minimum and Maximum

Rho = Sqrt (Reflected Power / Forward Power)
= Sqrt (4 W / 100 W) = 0.200

VSWR = (1 + Rho) / (1 - Rho)
= (1 + 0.200) / (1 - 0.200) = 1.50

Rho Min
= Sqrt (Reflected Power Min / Forward Power Max)
= Sqrt (2.067 W / 102.262 W) = 0.142

VSWR Min = (1 + Rho Min) / (1 - Rho Min)
= (1 + 0.142) / (1 - 0.142) = 1.33

Straight Talk About Directivity

Bird Technologies Group Applications Engineer

Rho Max
= Sqrt (Reflected Power Max / Forward Power Min)
= Sqrt (6.566 W / 97.763 W) = 0.259

VSWR Max = (1 + Rho Max) / (1 - Rho Max)
= (1 + 0.259) / (1 - 0.259) = 1.70

3c) Return Loss Min and Max

Return Loss
= 10 Log (Reflected Power / Forward Power)
= 10 Log (4W / 100 W) = -14.0 dB

Return Loss Min
= 10 Log (Reflect Power Min / Forward Power Max)
= 10 Log (2.067 W / 102.262 W) = -16.9 dB

Return Loss Max
= 10 Log (Reflect Power Max / Forward Power Min)
= 10 Log (6.566 W / 97.763 W) = -11.7 dB

Summary

As expected, the results of this step-by-step procedure agree with those listed in Example 1 at the beginning of this article. The "Directivity Chart" (see appendix) and "RF Calculator" (www.bird-electronic.com) will confirm as well.

After performing a number of calculations or reviewing the chart you will see a few trends that are worthy of note:

- 1) As directivity increases (e.g. 20, 30, 40 dB) errors decrease.
- 2) Directivity has a great impact on reflected power measurement error percentages. Forward power measurement error percentages are less affected.
- 3) Errors due to directivity vary for antennas and other loads with different levels of VSWR or return loss.
- 4) Directivity errors are independent of power levels. As an example, 3 mW, 50 W and 1 kW applications are all equally affected.

In conclusion, directivity has a straightforward effect on the accuracy of your power, VSWR and return loss measurements. Knowing the directivity specification of your measurement device (i.e. directional coupler, power meter, antenna monitor or analyzer) can go a long way in setting correct expectations. To optimize accuracy look for test and monitoring equipment with the highest level of directivity available.

Appendix

See the following attachments:

1) Directivity Chart

2) VSWR and Return Loss Chart