

Directional Hybrid Couplers

By Scott Buergin
Bird Technologies Group Engineer

When designing In-building RF Distribution Systems, one of the main objectives is to provide seamless high quality radio coverage throughout the targeted area. The distribution system may be very small consisting of just a single antenna or very large covering a number of floors using a combination of antennas and radiating cable. The process is similar in either case and eventually it will be necessary to split RF power at a desired proportion between 2-lines. The use of standard power dividers may be appropriate in a few cases but for the majority of the designs another device known as a directional coupler is needed. A directional coupler for this discussion is a 4-port device and basically consists of 2-transmission lines in close proximity to each other where the RF energy propagating down one transmission line couples over to the second line. The length of the transmission lines is a $\frac{1}{4}$ wavelength of the desired frequency and connections are made at both ends of each line. Ports 1 and 2 are on the driven line with the input at port 1. Port 3 is the coupled port adjacent to port 1 and port 4 is adjacent to port 2 and is typically terminated in a 50ohm load either internally or in many cases externally. Port 4 is isolated from input port 1 by 25dB typically. The coupled port, port 3 is isolated from output port 4 by the same level (see fig. 1.).

Coupling, dB	Thru-line Loss, dB	Power Ratio Thru-line/coupled
3.0	3.0	50/50
4.8	1.8	67/33
6.0	1.2	75/25
7.0	1.0	80/20
10.0	0.46	90/10
15.0	0.14	97/3
20.0	0.04	99/1
30.0	0.004	99.9/1

Using the uneven hybrid couplers allows the system designer to properly balance each leg of the distribution system to within a couple of dB. This ability ensures the losses from the signal source to any one antenna or to the end of any radiating line will be similar and the quality of the communications will be consistent throughout the intended coverage area. When a system is properly balanced it will be more efficient and the area that can be covered increases dramatically.

Hybrid couplers are used in many other applications such as signal samplers. These samplers can be used to measure incident and reflected power to determine VSWR, verify gain measurements, and monitor signal levels from input donor antennas. Hybrids used as samplers are placed in systems to monitor system performance and can be used to optimize system performance. Hybrid couplers have also been used to sample output power levels to provide feedback to regulate output levels. Hybrids are often used as a means to inject signals into a system without taking the system out of service. This is a very important feature when systems cannot be taken out of service to perform regular scheduled performance tests. Hybrids are a convenient and efficient way to tap off of repeater systems to feed in-building RF distribution systems or fiber transceivers without adversely affecting the power level of the primary system. Figure 2 below shows a typical hybrid being used as a sampler and how it is used to tap off from an existing repeater system.



Figure 1. 4-Port Directional Coupler

The Driven line is also referred to as the through port or thru-line and the insertion loss is determined by the relationship of signal level at the coupled port. Directional couplers, or sometimes referred to as uneven couplers, come standard in 8-different coupled values; 3db, 4.8dB, 6dB, 7dB, 10,dB, 15dB, 20dB, and 30dB. The use of the uneven couplers is essential when designing in-building RF distribution systems. The chart below list the couple values with the associated power split ratios and insertion losses.

Directional Hybrid Couplers

By Scott Buergin
Bird Technologies Group Engineer

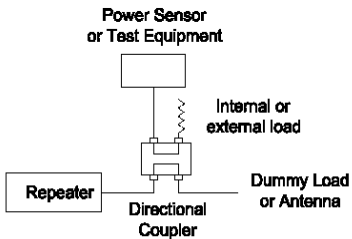

Figure 2a. Hybrid Sampler configured to measure Incident power

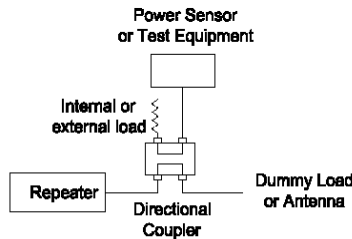

Figure 2b. Hybrid Sampler configured to measure Reflected power

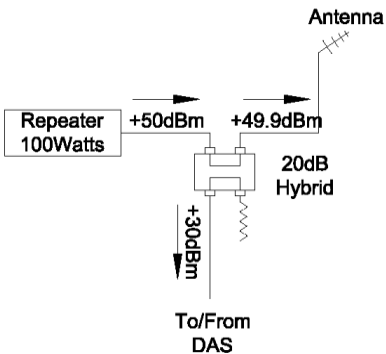

Figure 2c. Hybrid Coupled Repeater

When combining transmitters on to a single antenna, TX to TX spacing becomes very important. The closer the channel spacing the more difficult it is to combine them. A hybrid coupler is one way to combine two or more close channels while providing the required isolation. Isolators are needed between the transmitters and the hybrid to help prevent the production of unwanted IM products and to help protect the transmitters in cases of high VSWR or destructive instability due to mismatched loads. Second Harmonic filters are also recommended and are usually placed between the isolators and the hybrid couplers to provide harmonic rejection in excess of -80dB. The termination used on port 4 of the hybrid should have a continuous power rating of at least 50% of the combined transmitter power. If both transmitters are rated at 100 watts each then the hybrid termination should be rated for at least 100 watts. If more than 2-repeaters are being combined, then additional hybrids are used in a progressive design to ensure that each repeater has similar losses from the repeater output to the antenna. Figure 3 below is a simple 4-channel hybrid combiner with isolators and second harmonic filters. Each transmitter to the antenna experiences approximately 7dB of loss. That is a trade off for being able to combine 4-closely spaced transmitters on to a single antenna. If not for the use of hybrid couplers, this system would require at least 2-antennas and possible a number of bandpass and notch cavities.

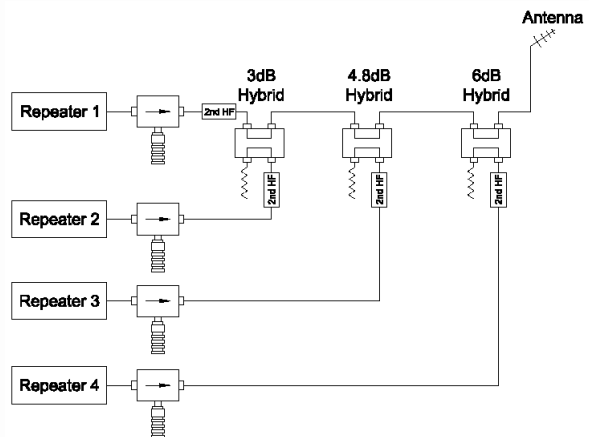

Figure 3. 4-Channel Progressive Hybrid Combiner
Approximately 7dB Loss Per Channel